



ICC Evaluation Service, Inc.
www.icc-es.org

Business/Regional Office ■ 5360 Workman Mill Road, Whittier, California 90601 ■ (562) 699-0543
Regional Office ■ 900 Montclair Road, Suite A, Birmingham, Alabama 35213 ■ (205) 599-9800
Regional Office ■ 4051 West Flossmoor Road, Country Club Hills, Illinois 60478 ■ (708) 799-2305

Legacy report on the 1997 Uniform Building Code™

DIVISION: 03—CONCRETE
Section: 03370—Specially Placed Concrete

TRIDIPANELS 3D/EVG

INSTEEL PANELMEX, S.A. DE C.V.
2310 M.L. KING AVENUE
CALEXICO, CALIFORNIA 92331

1.0 SUBJECT

Tridipanel 3D/EVG Panels.

2.0 DESCRIPTION

2.1 General:

The Tridipanel 3D/EVG Wall Panels are used in the construction of exterior and interior bearing and nonbearing walls, floors and roofs of buildings of all types of construction.

The Tridipanel 3D/EVG Wall Panel consists of a three-dimensional welded-wire space frame integrated with a polystyrene insulation core. The reinforcement/insulation module (RIM) is placed in position and wythes of concrete with a minimum f'c = 2,500 psi (17.2 MPa) are applied to both sides. See Figure 1 for panel details.

The strength and rigidity of the Tridipanel 3D/EVG wall panel is achieved through use of diagonal cross wires welded to the welded-wire fabric on each side. The assembly develops fully composite behavior in stiffness and shear transfer.

The insulation core is Type I expanded polystyrene foam plastic, complying with ASTM C 578-01, having a nominal density of 1.0 pound per cubic foot (16 kg/m³) as manufactured by Advance Foam Plastics (ESR-1006). The insulation has a flame-spread index of 25 or less and a smoke-developed rating of 450 or less when tested in accordance with UBC Standard 8-1 (ASTM E 84) at 1½-, 2- and 2½-inch (38, 51 and 63.5 mm) thicknesses. In accordance with UBC Standard 26-1 (NFPA 259), the insulations demonstrate a combustible content of 6,000 Btu/ft² (68.2 MJ/m²) or less.

The RIM is shop-fabricated with automated equipment. The welded-wire fabric complies with ASTM A 185 and is spaced ½, 5/8 or ¾ inch (12.7, 15.9 or 19.1 mm) from the insulation face. The diagonal truss wires and the wires used in the fabrication of the welded-wire fabric conform to ASTM A 82. The welded wire fabric is welded to the diagonal truss wires. The RIM configurations are shown in Figures 2, 3, 4, 5 and 6.

Figure 2 shows the typical panel, which has 2½ inches (63.5 mm) of insulation and a RIM thickness of 4 inches (101

mm). With 1½-inch (38 mm) concrete wythes, the overall wall thickness is 5½ inches (140 mm).

For walls that require less insulation or structural capacity, the "Minimum 3-D" section, shown in Figure 3, is available.

Where greater strength and bearing capacity are required, the configurations shown in Figures 4 and 6 are available.

Where less strength and bearing capacity are required, the configuration shown in Figure 2 is available.

2.2 Fire-resistive Construction:

The Tridipanel 3D/EVG walls have the fire-resistive ratings shown in Table 1.

The Tridipanel 3D/EVG Wall Panels are considered noncombustible construction, provided all portions of the foam plastic are covered by a minimum of 1 inch (25.4 mm) of concrete.

2.3 Design:

2.3.1 General: The design values in this section apply when panels are detailed to distribute loads equally to each wythe. Both wythes must be fully supported.

2.3.2 Flexural Strength: The flexural strength of the Tridipanel 3D/EVG panels shown in Figures 2 through 6 for nonbearing, exterior wall applications subject to wind loads, has been determined in accordance with the provisions of Chapter 19 of the 1997 Uniform Building Code™ (UBC) (ACI 318-95), and is shown in Figure 12.

2.3.3 Axial-flexural Strength: The combined axial-flexural strength of the Tridipanel 3D/EVG panels shown in Figures 2 through 6 for bearing applications has been determined in accordance with the provisions of Chapter 19 of the UBC (ACI 318-95), and is shown by means of the interaction diagrams in Figures 7 through 11, respectively.

2.3.4 Out-of-plane Shear Strength: Design out-of-plane shear strength of the Tridipanel 3D/EVG panels for transverse load resistance must be determined in accordance with the following equation:

φ Vn = φ b d [0.5 (f'c)^(1/2)]

For SI: φ Vn = φ b d [0.04 (f'c)^(1/2)]

where:

φ = 0.85.

Vn = Nominal shear strength.

b = Width of compression face, inches (mm).

d = Distance from extreme compression fiber to a centroid of longitudinal reinforcement, inches (mm).

ICC-ES legacy reports are not to be construed as representing aesthetics or any other attributes not specifically addressed, nor are they to be construed as an endorsement of the subject of the report or a recommendation for its use. There is no warranty by ICC Evaluation Service, Inc., express or implied, as to any finding or other matter in this report, or as to any product covered by the report.



f'_c = Specified compressive strength at 28 days, psi (N/mm²).

2.3.5 Deflection: The out-of-plane deflection of the Tridipanel 3D/EVG panels due to transverse loads must be determined in accordance with standard engineering practice and assuming the effective moment of inertia to be one-fifth the calculated gross moment of inertia.

2.3.6 In-plane Shear Strength: When the Tridipanel 3D/EVG panels are used as shear walls to resist lateral loads, the walls must be designed in accordance with Section 1911.10 of the UBC (ACI 318-95, Section 11.10). In Seismic Zones 2, 3 and 4, the walls must be designed in accordance with Section 1921.6 of the UBC (ACI 318-95, Section 21.6). The total thickness of the wall, h , must be taken as the sum of the two wythes.

2.3.7 Openings in Walls: Loads over wall openings must be calculated, and the portion of the wall above the opening must be designed as a beam in accordance with reinforced concrete strength design principles and the requirements of Chapter 19 of the UBC (ACI 318-95). Wall sections adjacent to such openings must be designed to resist additional loads due to the presence of the opening (such as reactions from the wall section above the opening, additional lateral loads due to wind on doors or windows within the opening, etc.).

2.4 Installation:

For each project, plans, specifications, and structural calculations must be submitted to the building official for approval, and must show particular job details relating to design and construction. The calculations must be based on the loads and loading conditions required by the UBC. The calculations must confirm that the panel loads do not exceed those allowed by Section 2.3 of this report. When required by the building official, plans and calculations must be signed and sealed by a registered design professional. Since this report only recognizes panel strength, fire-resistance, and noncombustible construction, information pertaining to the code conformance of other aspects of the building design must be submitted to the building official for approval.

Foundation walls, footings, and other supporting structures receiving Tridipanel 3D/EVG panels must be level and free of dirt and loose material. Reinforcement for anchoring panels to support must be as shown on the plans.

The Tridipanel 3D/EVG panels must be plumb and true in their final location, with respect to location and alignment as shown on the plans. Panels must be temporarily braced as required to resist wind and the shotcreting operation. Embedded hardware and accessories shown on drawings must be installed in the proper location and fastened by wires or other appropriate means.

Concrete must be applied to the outside and inside of the Tridipanel 3D/EVG panel to the thickness shown on the plans. The exterior and interior wythes must be portland cement concrete applied by the shotcrete process, using either the "dry" or "wet" process in accordance with the provisions of the Guide to Shotcrete (ACI 506R-85) and the Specification for Materials, Proportioning, and Application of Shotcrete (ACI 506.2-77) (revised 1983). Materials must conform to Chapter 2 of those documents. Additionally, aggregate must be "Gradation No. 1," in accordance with Table 2.1 of ACI 506R-85, and the concrete compressive strength, f'_c , must not be less than 2,500 psi at 28 days. In addition, the shotcrete application must also comply with Section 1924 of the UBC.

In lieu of applying concrete by the shotcrete process, the wall panels may be set between aluminum, steel, or wood forms. The concrete is then placed from the top, in a manner that complies with the UBC. Concrete compressive strength,

f'_c , must not be less than 2,500 psi (17.2 MPa) at 28 days. Concrete aggregate must conform to ASTM C 33, referenced in Section 1903.3.1 of the UBC. Poured wythes of concrete must be no less than 2 inches (51 mm) thick.

Concrete materials and proportions must comply with Section 1904 of the UBC for durability. Special care must be taken to ensure complete filling of space between the insulation and the welded-wire fabric. The shotcrete cover over the welded-wire fabric must not be less than $\frac{3}{4}$ inch (19.1 mm) in thickness, with a minus tolerance of $\frac{1}{4}$ inch (6.4 mm).

Allowable construction tolerances must be as noted in the Specifications for Structural Concrete for Buildings (ACI 301).

The interior and exterior finishes must be applied as shown on the plans and in accordance with the UBC. Evaluation of such finishes is beyond the scope of this report.

The manufacturer's published installation instructions, Publication 1-C, dated May 1, 1997, and the plans and specifications, must be strictly adhered to, and a copy of the manufacturer's instructions must be available on the jobsite at all times during installation.

2.5 Special Inspection:

Continuous special inspection of shotcrete must be in accordance with Sections 1701.5 and 1924 of the UBC. The special inspector's duties are specified in Sections 1924.10 and 1924.11 of the UBC, and include verifying equipment; weather limitations; reinforcement and its embedment and placement; joints and form work; nozzle man position; thickness gages; and shotcrete mixing and placement (voids, rock pockets, sand streaks, consistency, consolidation, coverage, rebound, finish, cure). The special inspector's duties also include checking the finished job for defects and corrective action; and preparing test panels or cores. Coring areas shall be selected by the design engineer in accordance with Section 1924.11.2 of the UBC. Continuous inspection of poured concrete must be in accordance with Section 1701.5.1 of the UBC. Here, the special inspector's duties include verification of forms, concrete slump, temperature, air content, placement, consolidation, and preparation of test cylinders.

2.6 Identification:

All packaging of Tridipanel 3D/EVG Wall Panels covered by this report must bear the name and trademark of the manufacturer (Insteel Panelmex, S.A. de C.V.) and the evaluation report number (ER-5618), for field identification.

The face or edge of the insulation on each Tridipanel 3D/EVG panel must be identified in accordance with ESR-1006.

3.0 EVIDENCE SUBMITTED

Data in accordance with the Acceptance Criteria for Concrete Floor, Roof and Wall Systems and Concrete Masonry Wall Systems (AC15), dated June 2003, and a quality control manual.

4.0 FINDINGS

That the Tridipanel 3D/EVG™ Wall Panels described in this report comply with the 1997 Uniform Building Code™, subject to the following conditions:

- 4.1 The Tridipanel 3D/EVG Wall Panels are delivered, stored and handled in such a manner that the insulation is not punctured and the welded-wire fabric is not bent.**
- 4.2 Plans, specifications and structural calculations are submitted to the building official for approval. When**

required by state statutes or the authority having jurisdiction for approval, applications for a permit involving Tridipanel 3D/EVG Wall Panels are accompanied by documents signed and sealed by a registered design professional.

4.3 Structural evaluation in this report is limited to an evaluation of panel strength only; information pertaining to the code conformance of other aspects of the building design is submitted to the building official for approval.

4.4 Cuts in panel wythes, holes or other openings in panels, etc., are not permitted unless shown on approved plans.

4.5 The Tridipanel 3D/EVG Wall Panels are installed in accordance with this report and the manufacturer's installation instructions as noted in Section 2.4 of this report.

This report is subject to re-examination in one year.

TABLE 1—FIRE-RESISTIVE RATINGS OF TRIDIPANEL 3D/EVG WALLS

PANEL TYPE (AND FIGURE)	FIRE-RESISTIVE RATINGS	
	Carbonate Aggregate	Siliceous Aggregate
Standard panel (Figure 2)	1½ hours	1 hour
Minimum panel (Figure 3)	1½ hours	1 hour
Maximum panel (Figure 4)	1¾ hours	1½ hours
Two-hour-rated panel (Figure 5)	2 hours	2 hours
No. 14 gage panel (Figure 6)	1½ hours	1 hour

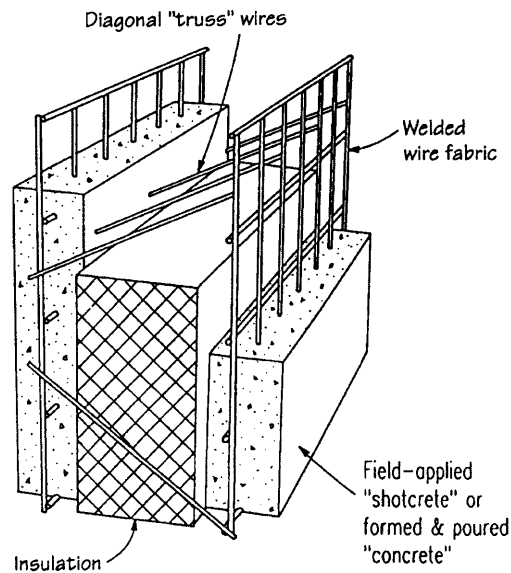

FIGURE 1—THE TRIDIPANEL 3D/EVG WALL PANEL

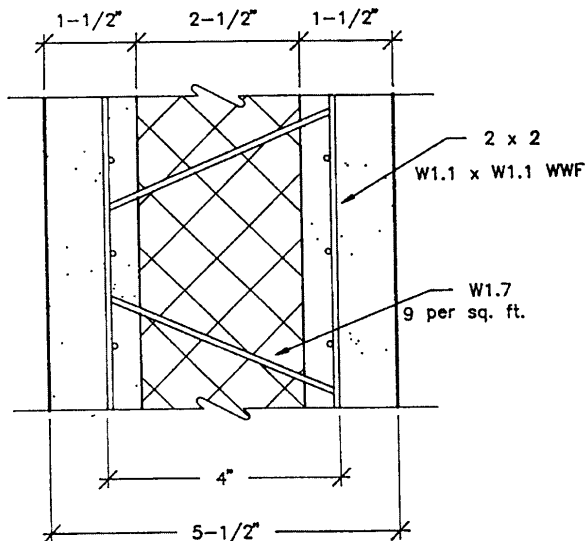

FIGURE 2—TYPICAL TRIDIPANEL 3D/EVG SECTION

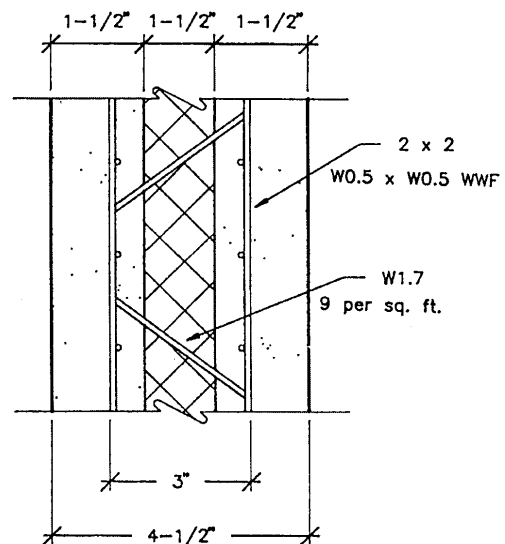

FIGURE 3—TRIDIPANEL 3D/EVG SECTION

For SI: 1 inch = 25.4 mm, 1 square foot = 0.0929 m².

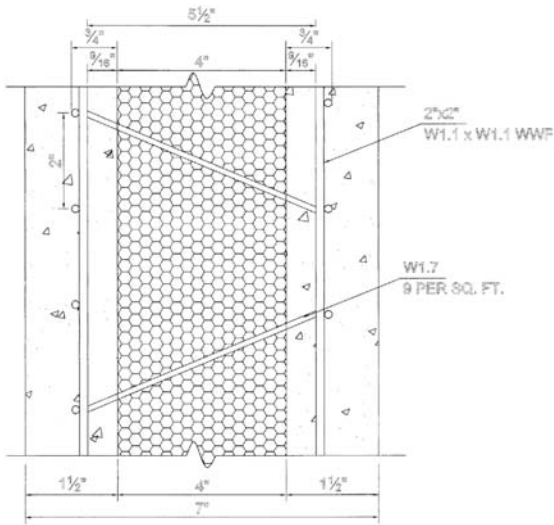

FIGURE 4—MAXIMUM TRIDIPANEL 3D/EVG SECTION

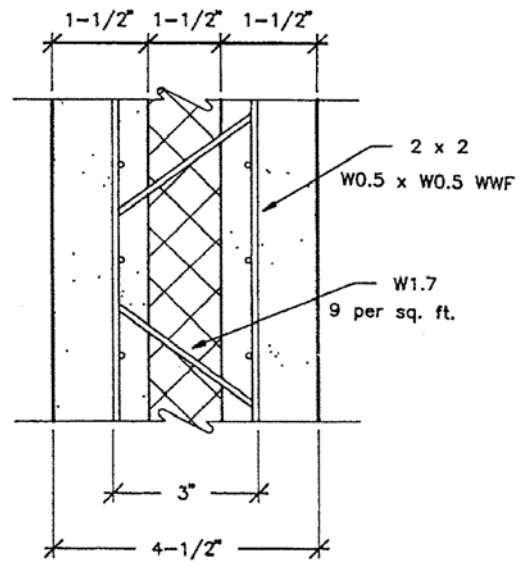

FIGURE 5—TWO-HOUR RATED TRIDIPANEL 3D/EVG SECTION

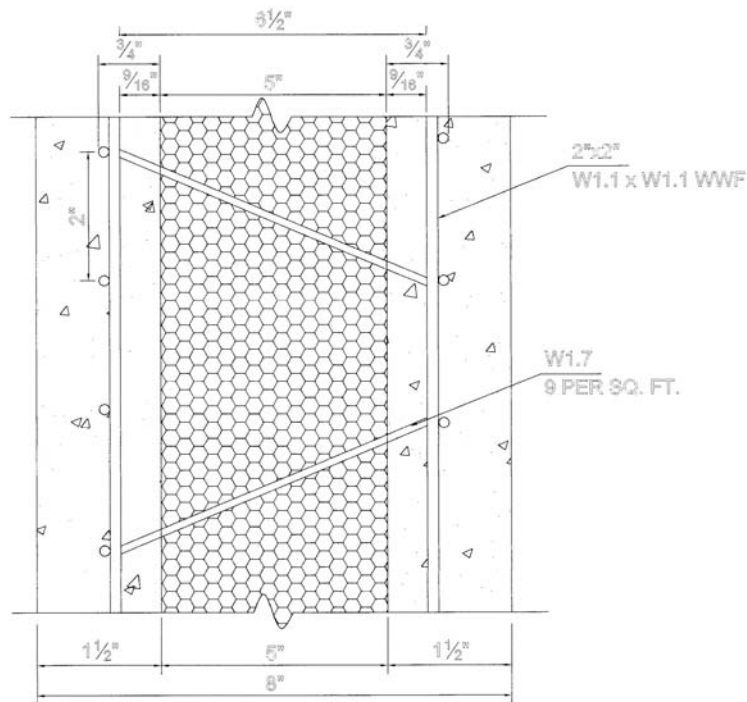

FIGURE 6—NO. 14 GAGE TRIDIPANEL 3D/EVG SECTION

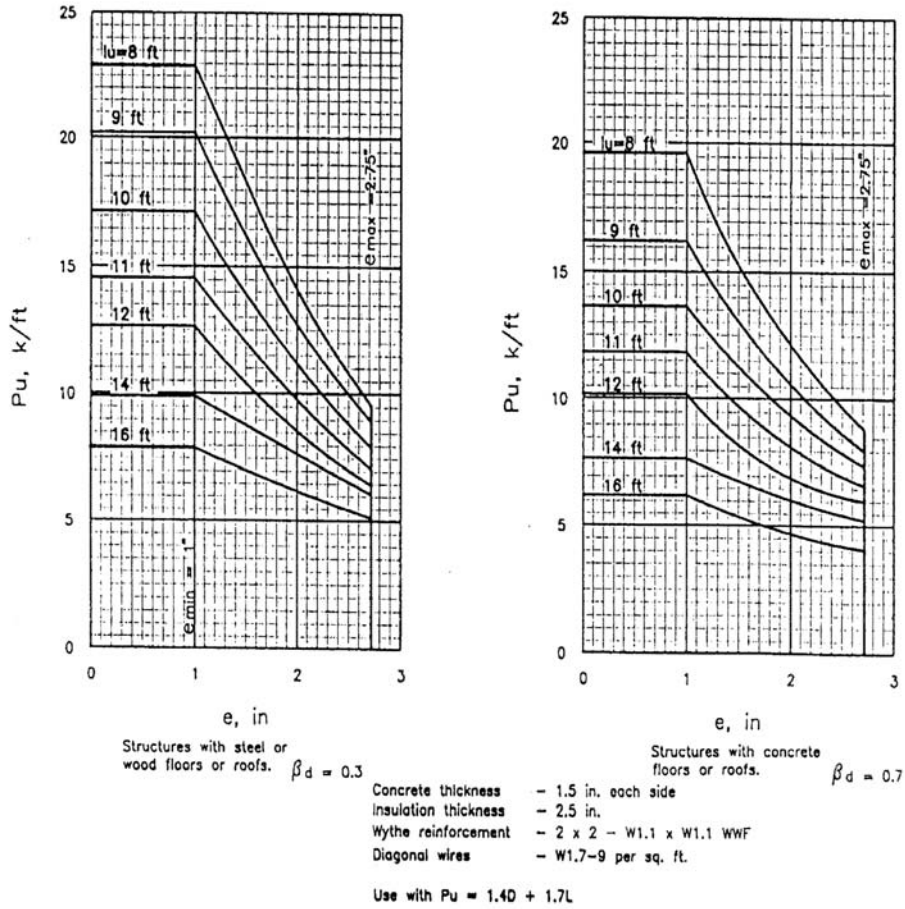

FIGURE 7—DESIGN AXIAL LOADS AND ECCENTRICITIES: STANDARD TRIDIPANEL 3D/EVG SECTION

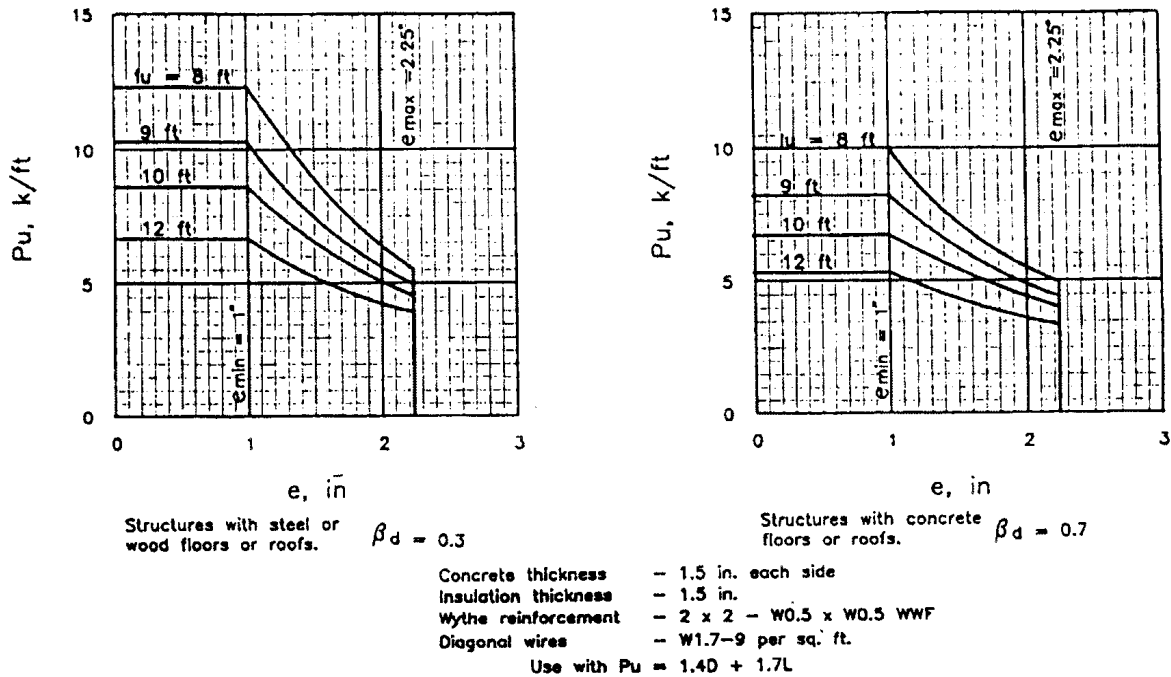

FIGURE 8—DESIGN LOADS AND ECCENTRICITIES: MINIMUM TRIDIPANEL 3D/EVG SECTION

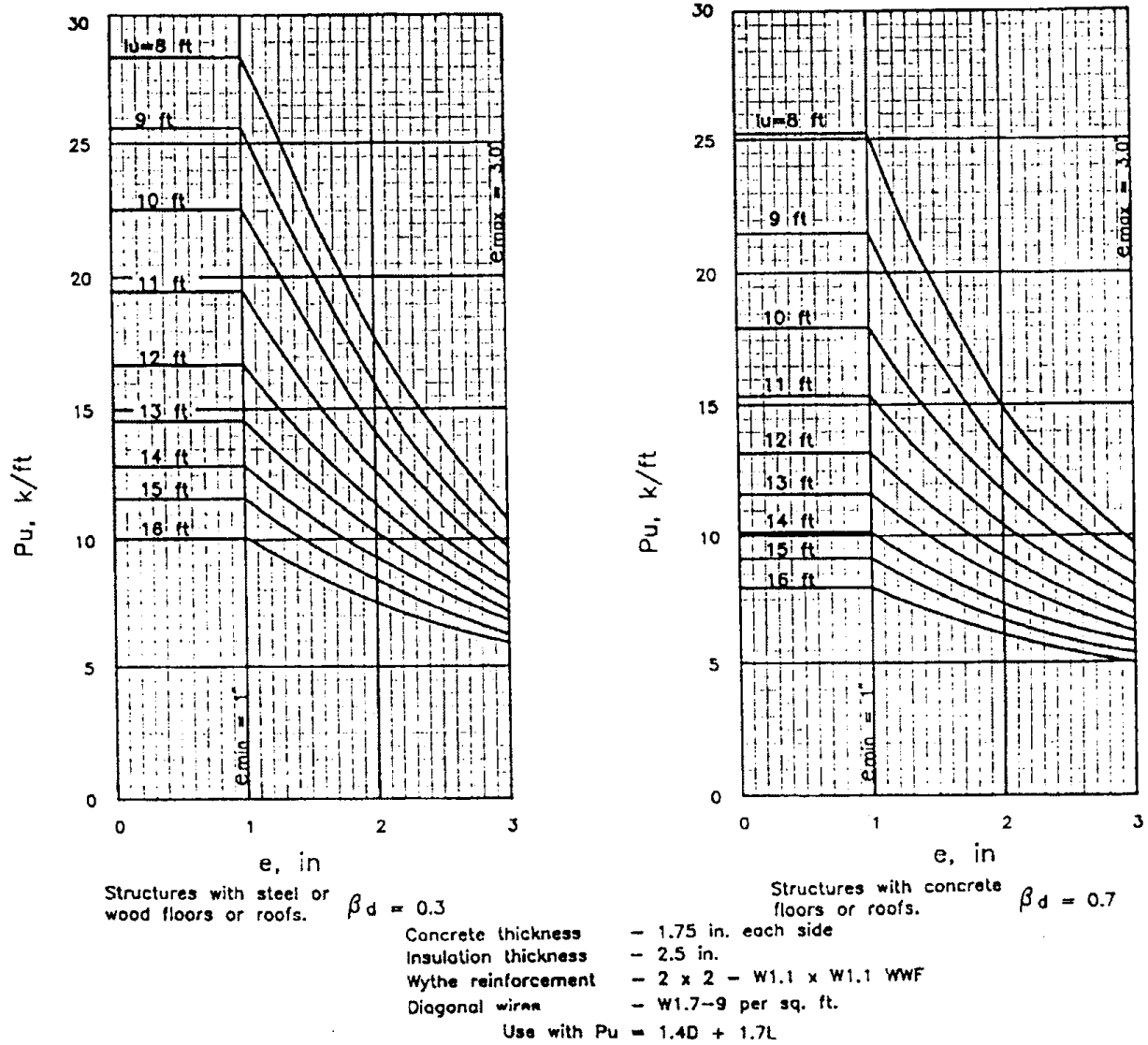

FIGURE 9—DESIGN LOADS AND ECCENTRICITIES:
MAXIMUM TRIDIPANEL 3D/EVG SECTION

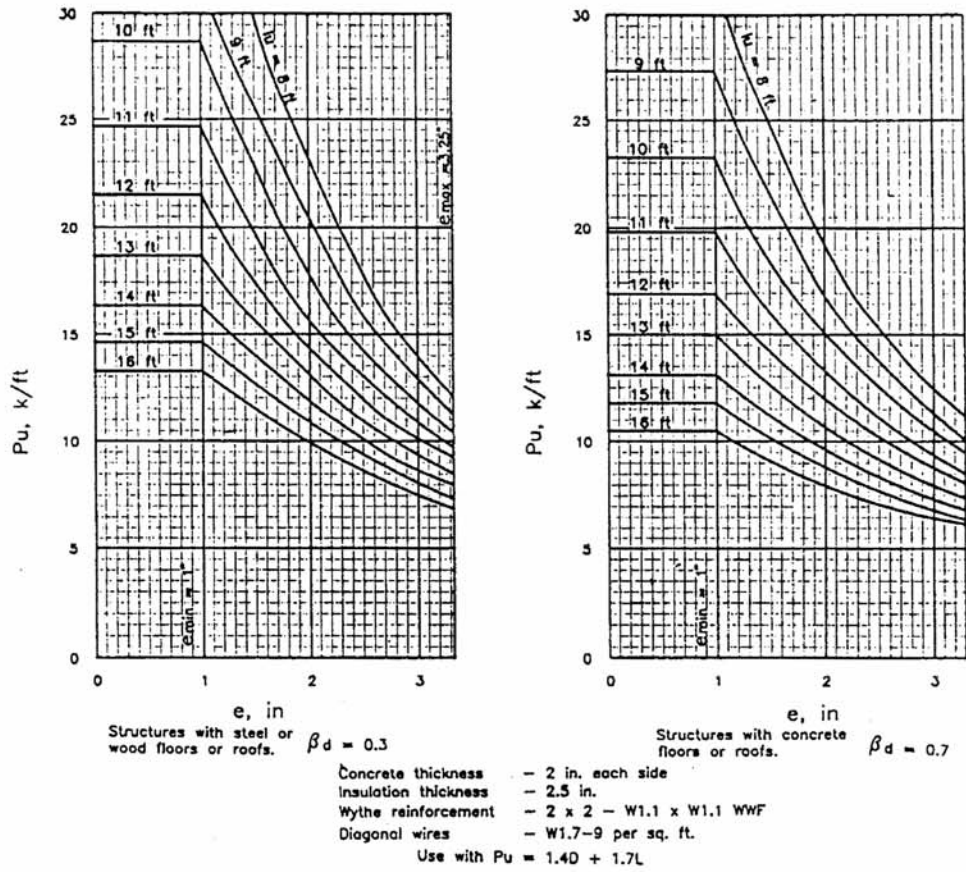
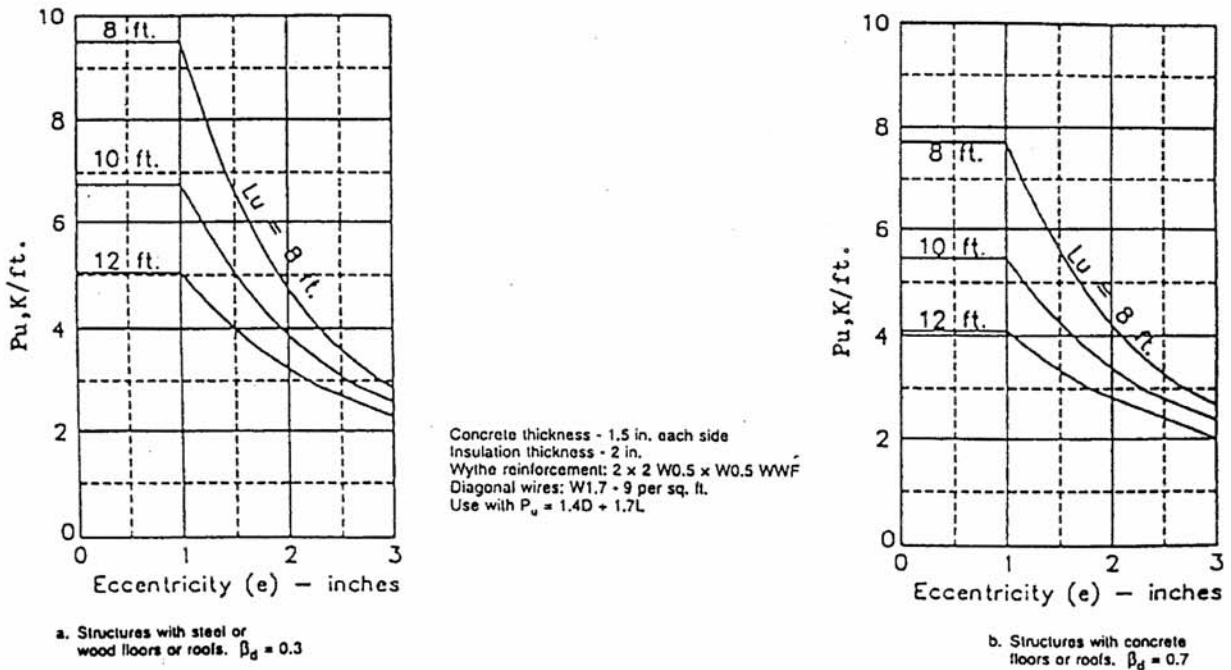

FIGURE 10—DESIGN LOADS AND ECCENTRICITIES:
2-HOUR-RATED TRIDIPANEL 3D/EVG SECTION



For SI: 1 inch = 25.4 mm, 1 square foot = 10.86/m², 1 k/ft = 14.6 kN/m, 1 foot = 304.8 mm.

FIGURE 11—DESIGN LOADS AND ECCENTRICITIES:
NO. 14 GAGE TRIDIPANEL 3D/EVG SECTION

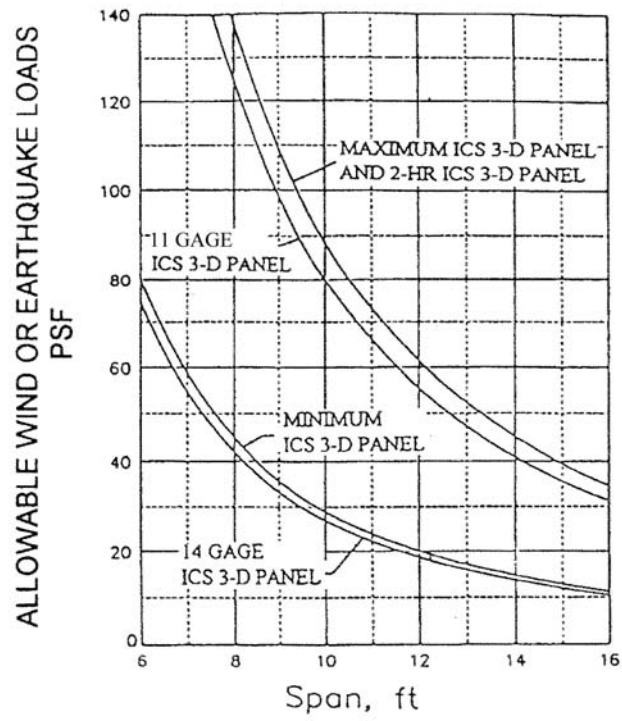

FIGURE 12—ALLOWABLE WIND OR EARTHQUAKE LOADS ON TRIDIPANEL 3D/EVG WALLS

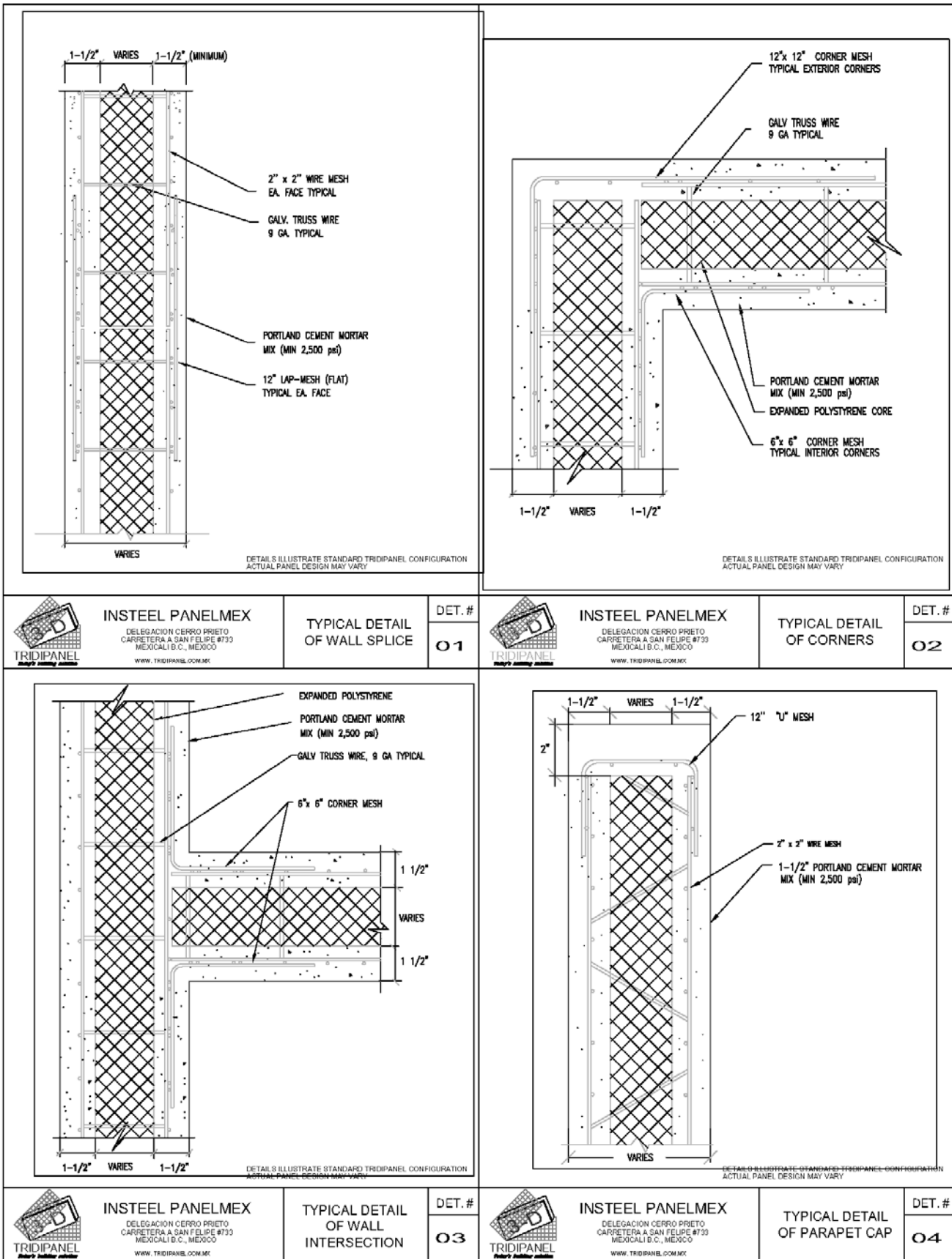
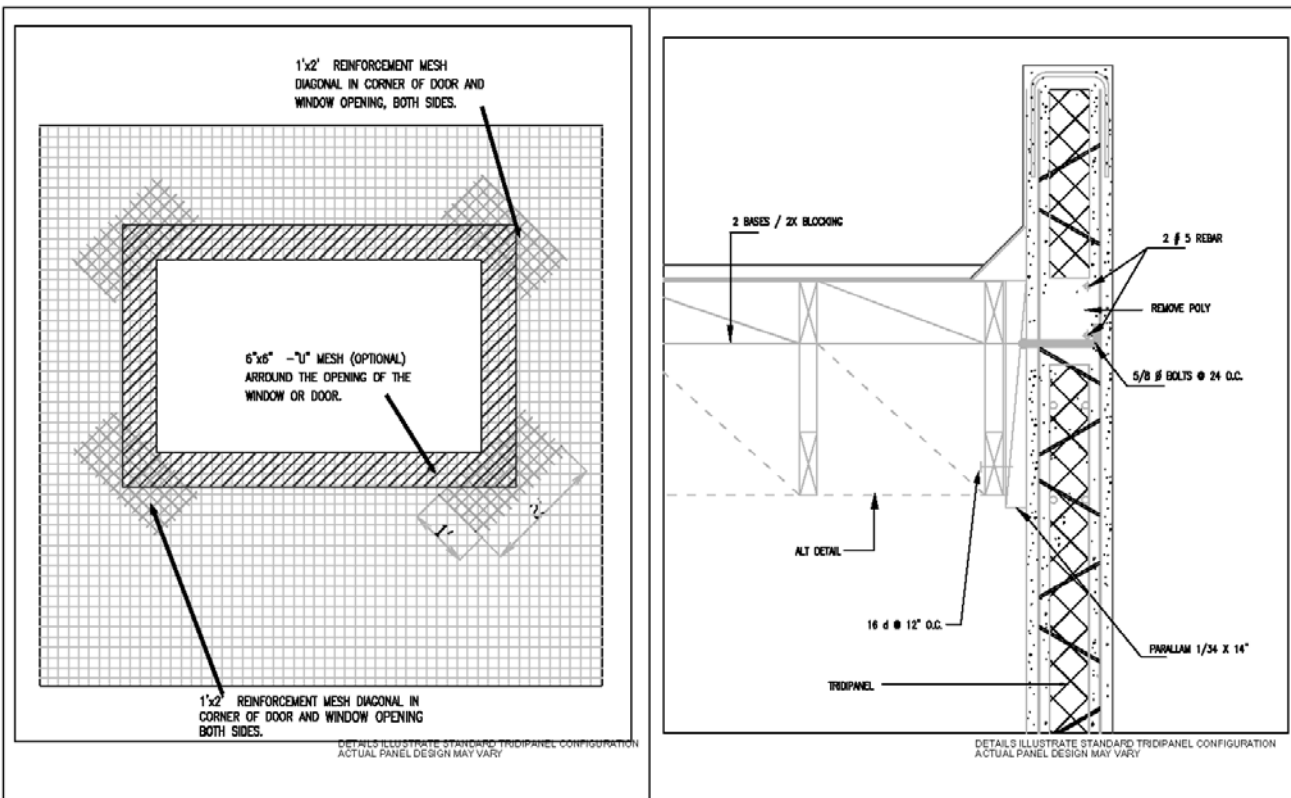

FIGURE 13—TYPICAL INSTALLATION DETAILS



INSTEEL PANELMEX
 DELEGACION CERRO PRIETO
 CARRETERA A SAN FELIPE #733
 MEXICALI B.C., MEXICO
 WWW.TRIDIPANEL.COM.MX

TYPICAL DETAIL OF REINFORCEMENT IN DOORS AND WINDOWS CORNERS
 DET. # 05

INSTEEL PANELMEX
 DELEGACION CERRO PRIETO
 CARRETERA A SAN FELIPE #733
 MEXICALI B.C., MEXICO
 WWW.TRIDIPANEL.COM.MX

TYPICAL DETAIL OF FLOOR/ROOF LEDGER CONNECTION
 DET. # 06

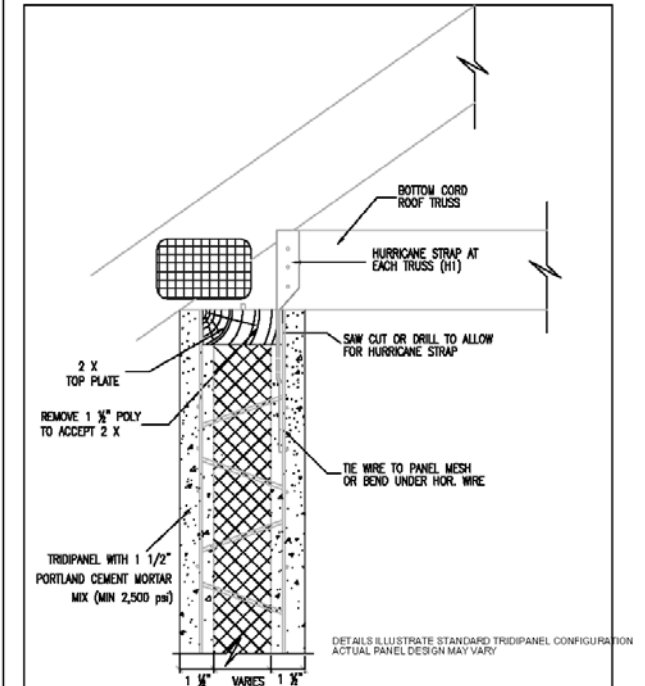

INSTEEL PANELMEX
 DELEGACION CERRO PRIETO
 CARRETERA A SAN FELIPE #733
 MEXICALI B.C., MEXICO
 WWW.TRIDIPANEL.COM.MX

TYPICAL DETAIL OF TRUSS CONNECTION WITH TRIDIPANEL WALL
 DET. # 07

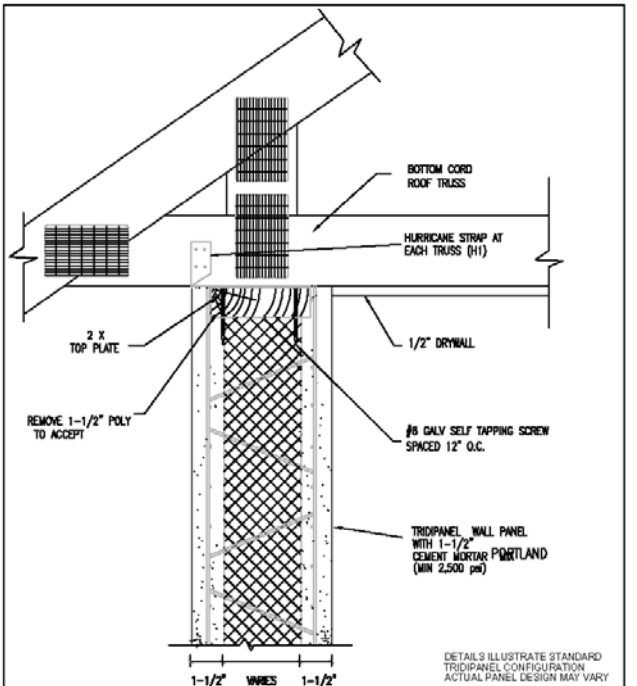

INSTEEL PANELMEX
 DELEGACION CERRO PRIETO
 CARRETERA A SAN FELIPE #733
 MEXICALI B.C., MEXICO
 WWW.TRIDIPANEL.COM.MX

TYPICAL DETAIL OF TRUSS CONNECTION WITH TRIDIPANEL WALL
 DET. # 08

FIGURE 13—TYPICAL INSTALLATION DETAILS—(Continued)

