

**TRIDIPANEL**

## ASSEMBLY MANUAL FOR THE **TRIDIPANEL** 3-D/EVG BUILDING SYSTEM

The **TRIDIPANEL** 3-D/EVG system is unique in providing a fast economical and easy construction method, which offers the builder a premier, finished concrete wall or building that withstands a lot more stress than the regular building methods. This system allows the designer to effectively use the same material in both load bearing and non-load bearing applications, straight, curved or angled walls as for single or multi-story buildings

It is adaptable to all types of structures from affordable housing to upscale homes, motels, condominiums and warehouses as well as schools and strip malls. Very attractive low cost concrete privacy walls can also be constructed with **TRIDIPANEL** 3-D/EVG.

What follows is a general description of the recommended construction procedure. However, this system is so versatile it is impractical to attempt to address all situations in this manual. Please call for more information or answers to specific questions. Our technical staff is both qualified and eager to help you.



**TRIDIPANEL**

Today's Building solution

Expanded Polystyrene

Diagonal truss wires

2" x 2" Welded wire fabric.

Field applied concrete.

**HADRIAN TRIDI-SYSTEMS**

**E-Mail: [panel@tridipanel.com](mailto:panel@tridipanel.com)**

**Phone 888-682-2228**

## Storage and care of Panels

**TRIDIPANEL** is commonly delivered on flatbed trucks. Their lightweight means they can be unloaded either by hand or forklift truck. Gloves are recommended to be worn when handling these products. The panels can then be stored on a flat surface outdoors without protective covering. However, due to their lightweight, care must be taken to prevent damage from strong winds. Stacks of panels should be tied to adequate supports to prevent damage. Storage outside for several weeks is not a problem. Photo 1

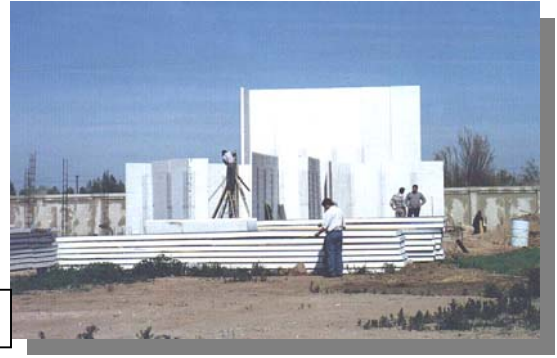

1

## Foundations

Foundations are very similar to the traditional method (Photo 2 & 3) and often plans will specify that a system of metal anchors be placed in the wall footing or slab to secure the panel bases. Lengths of straight rebar extending vertically out of the concrete commonly are used for this purpose. **Care must be taken** to insure that the proper line, grade, and spacing of these anchors are maintained. As can be seen in Photos 4, the panels should be placed so that the rebar is set between the mesh and the polystyrene. This arrangement provides easy wall alignment.

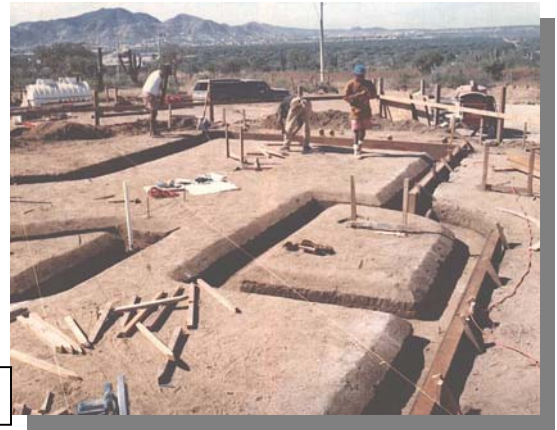

2

When panels are to be placed on existing slabs, holes may be drilled on-line to house lengths of rebar dowels. Other methods of anchoring to slabs also may be used like epoxy glues. Photo 5



3

In all cases be sure that all mud and debris is removed from any area prior to setting panels in place. The foundation design should conform to Section 2615 of the Uniform Building Code or the appropriate governing code.

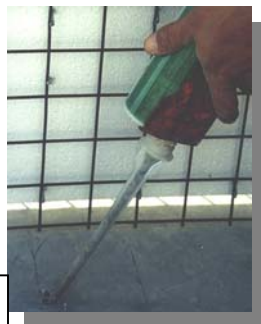

5



4

## Handling of TRIDIPANEL ´s

Since panels typically weigh only 1.20 pounds/ ft.2, one of the best features of using 8 ft. or 12 ft. panels is that they can easily be set in place or stacked using only a one or two man crew. Crews should be cautioned, however, when moving panels in windy weather. Photo 6 shows how easy panel handling can be accomplished.

## Assembly of panel sections.

Before assembly begins, it's important that the items on the list at the end of these instructions should be available at the job site. Also needed will be a sufficient supply of lumber for braces. A stack of panels should be moved as close to the job site as possible. Once the footing is clean, work can begin at any corner with uncut panels.

A string line is usually run to establish each wall line. The first two uncut panels are placed on-line (forming a corner) and the adjacent panels are clamped together using a pneumatic fastener tool. This easy to use handheld tool is indispensable for connecting panels to each other rapidly. Fastening systems such as the Stanley Spenax Pneumatic Gun or manually attached wire ties may also be used. **Photo 7 & 8** shows a pneumatic tool in use.

After the first two panels are firmly attached, the panel tops can be brought online using appropriate bracing. The type of bracing required will depend on several conditions, i.e., panel height, wind conditions, etc.

**Photo 9 & 10** shows one type of simple bracing commonly used. All bracing should be located on the same side of the wall opposite the side, which will receive concrete first. (Care must be used when anchoring the bracing to the ground to be sure settlement does not occur. Throughout erection checks should be made to insure that alignment is maintained. A 4-ft. level is

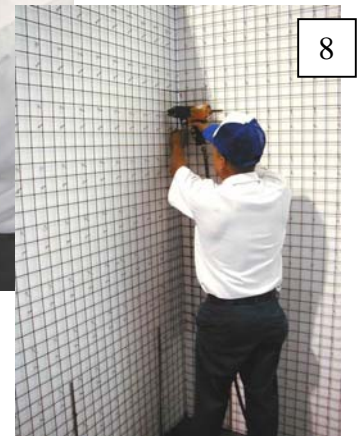
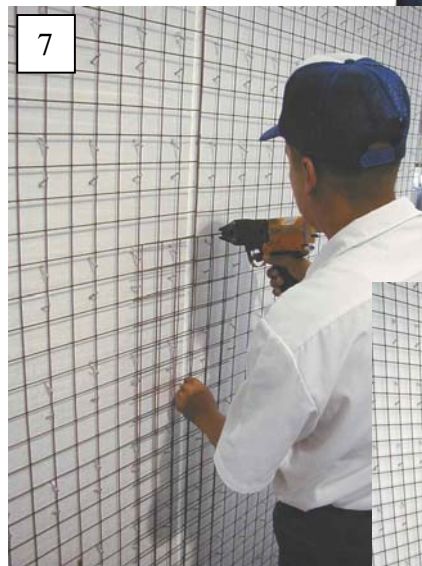
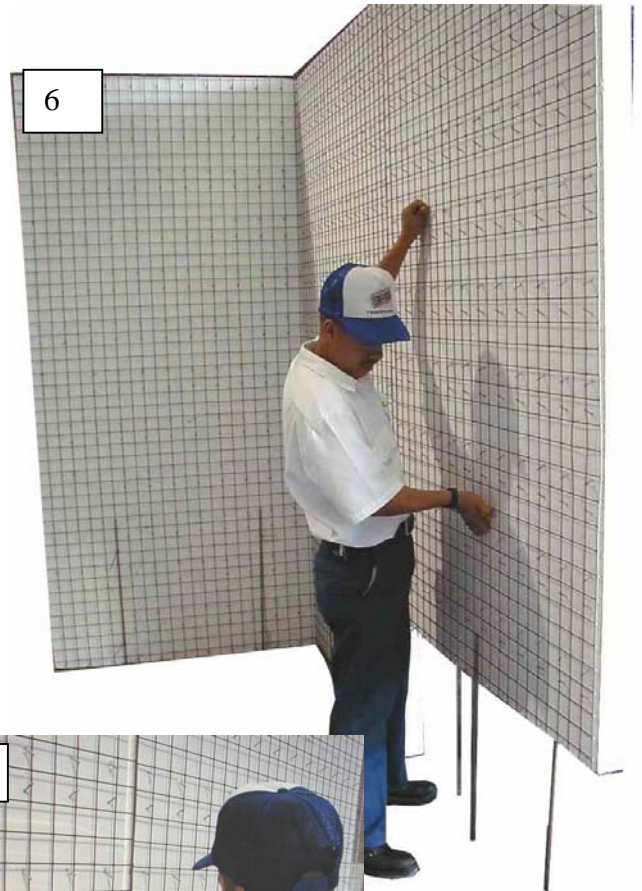

required here.

Strips of 2" x 2" cover mesh are used to reinforce panel seams. These strips are easily attached to the panels also using the pneumatic fastening gun. Be sure that these mesh strips fit close against the panel mesh. Pieces of mesh preformed with 90° bends are used on the inside and outside of corners (be sure to use 2' wide corner mesh on outside corners and 1' wide on inside corners) **Photo 11.** Unshaped mesh is also available for certain applications at the top or bottom of walls.

### V . Openings

With this unique panel system, openings for doors and windows can be cut out both before or after panel erection. In either condition several different methods can be used. In all cases precise measurement and layout is essential. It is important to follow door and window instructions regarding frame tolerances. Once the opening is marked, cutting can begin. **Photos 12,13 & 14.**

The recommended panel cutting method is to use a handheld variable speed reciprocating saw with a minimum 8" long metal cutting blade with 20-24 teeth per inch. Note: If electrical power is not available at the job site, panels can be cut using a regular pair of bolt cutters (*we recommend the 18" long handle ones*) to snip the mesh wires, followed with a hand saw to cut out the polystyrene. See "tools" in this document.

Special care should be taken when cutting openings by any method to insure that the cuts are precise and are perpendicular to the panel face. **(Protective eyewear should be worn when using any electrically powered cutting tool.)**

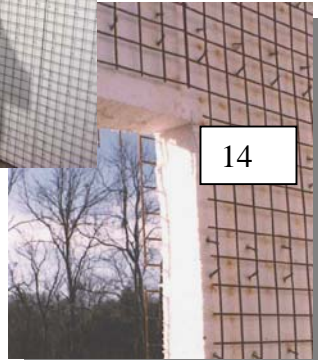
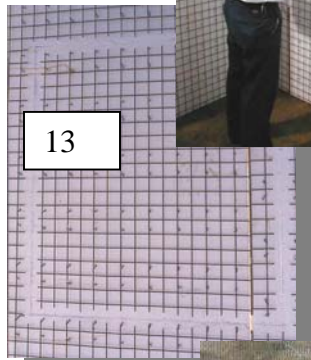
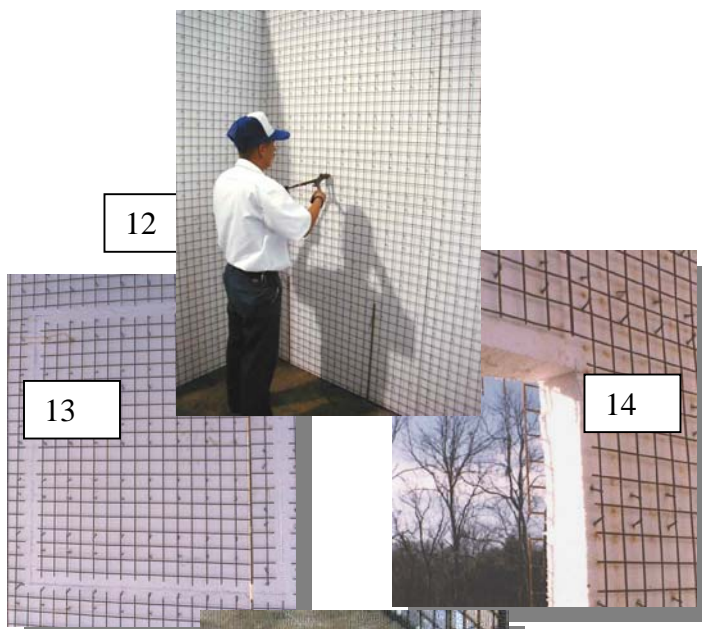
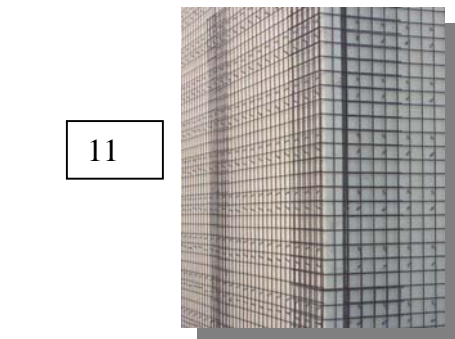

18" Bolt Cutters Recommended

Notice in **Photo 15** that for most door and window openings, pieces of pressure treated 2 x 4 lumber Can act as a hidden frame by placing them recessed inside the 3-D Panel, provided additional polystyrene is removed equal to the depth of the lumber to be installed, This polystyrene can be easily removed with a keyhole saw. The 2 x 4 framework is then stapled to the surrounding mesh and becomes a very secure nailer for the standard door or window frame. **Photo 16**

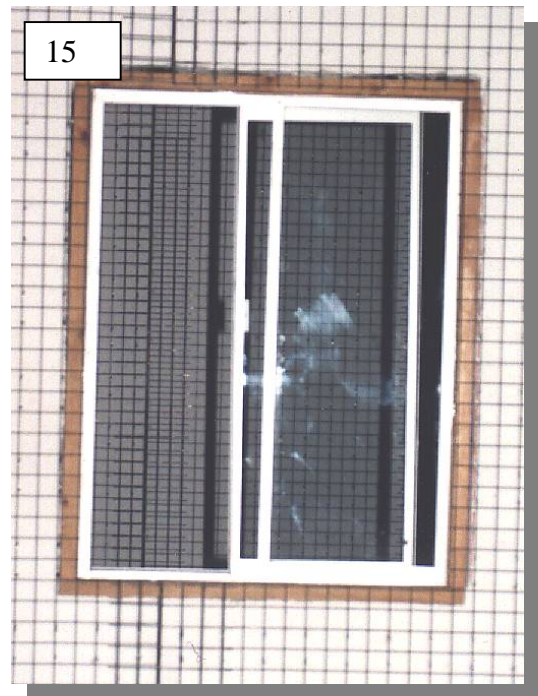

Strips of cover mesh are usually placed diagonally above and below corners and on both sides to prevent corner cracks from developing in the concrete covering. See **Photo 17 & 18** for an example of this type cover mesh placement. U-shaped mesh is also used to rein force window openings in some cases.

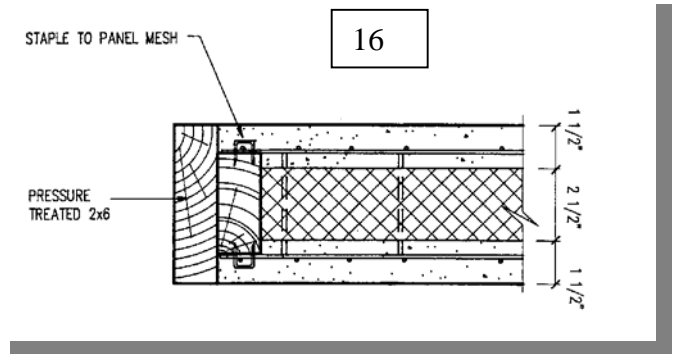

## VI. Walls/roof connections

The 3-D wall system works well with all conventional roof systems if required.

Figure 19 shows details of a typical flat roof and load-bearing truss attached to the 3-D wall. Figure #14 shows the standard details for a sloped truss. Notice that here that PT 2 x 6 lumber has been buried in the top of the panel by the method just described in Section V. The type of roof to be utilized with 3-D construction will be determined by different aspects. These being, the client, the engineering and the building codes. There are a lot of ways to solve a roof. (Please be sure to check the wind requirements in your area for special straps.)

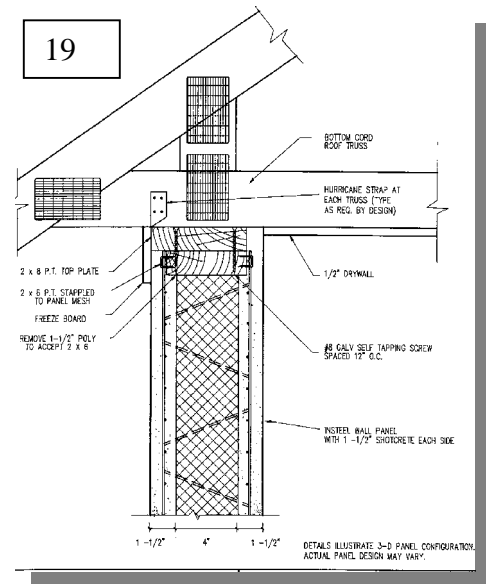

It can be a flat 3-D Roof, Photo 20.



It can be a Vaulted 3-D roof. Photos 21& 22

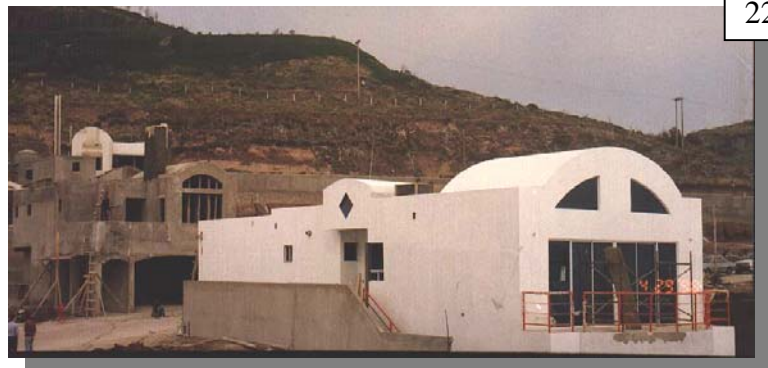

It can be a Pitched 3-D roof, and even A 3-D dome roof. Photos 23 & 24

23

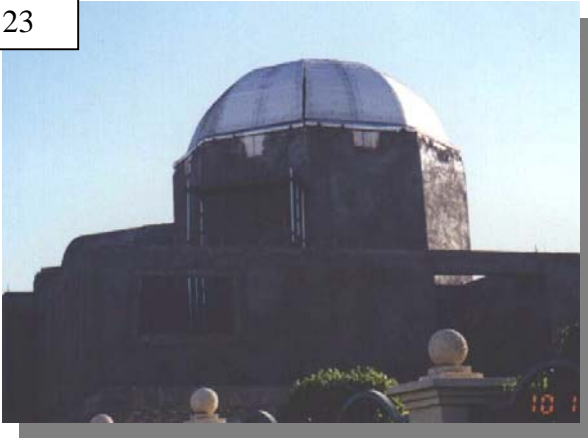

24

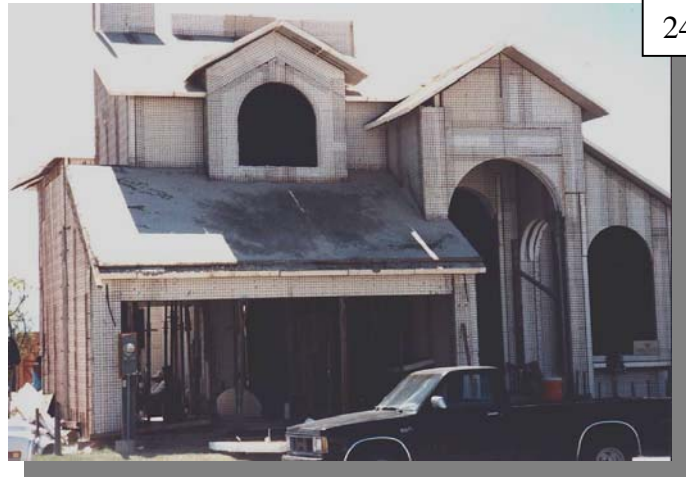

Or, if you prefer, it can be a Regular Wood truss roof. Photos 25 & 26.



25



26

## **VII. Utilities**

Another great feature of this system is the way it accommodates utilities. Once 3-D panels are secured in place, installation of utilities can begin. The gap between the polystyrene core and the layer of wire mesh provides an excellent area for encasing both electrical conduit and water pipe. Gas line and phone cable can also be run in this area. Photo 27.

27

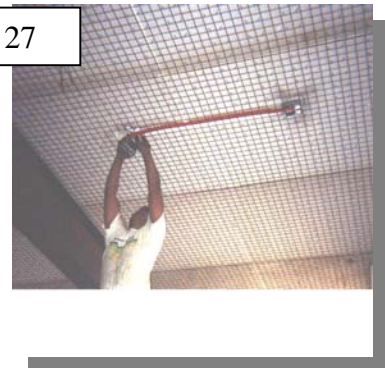

Simply run the pipe or conduit in this space avoiding the galvanized stay wires in the panels where possible. Words of caution here--the stay wires are an integral structural part of the system, and as such cannot be randomly cut. Consequently, cut no more than four wires in any given run in a panel. Photo 28 is a good example of electric conduit run inside a panel. The 2 x 2" cover mesh provides a very convenient place to tie pipe and boxes in place.

When installing wall switch **boxes** it will be necessary to remove a portion of both the mesh and the polystyrene material. Important, remove only that material, which is necessary. Set boxes out of the panel far enough so they will meet the finished wall after it is shotcreted. (In most cases this will be 5/8" beyond the face of the mesh, but always check your plans to be sure.) Photo 29.

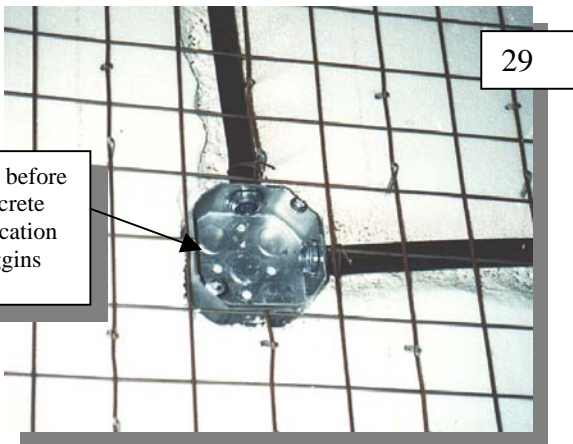
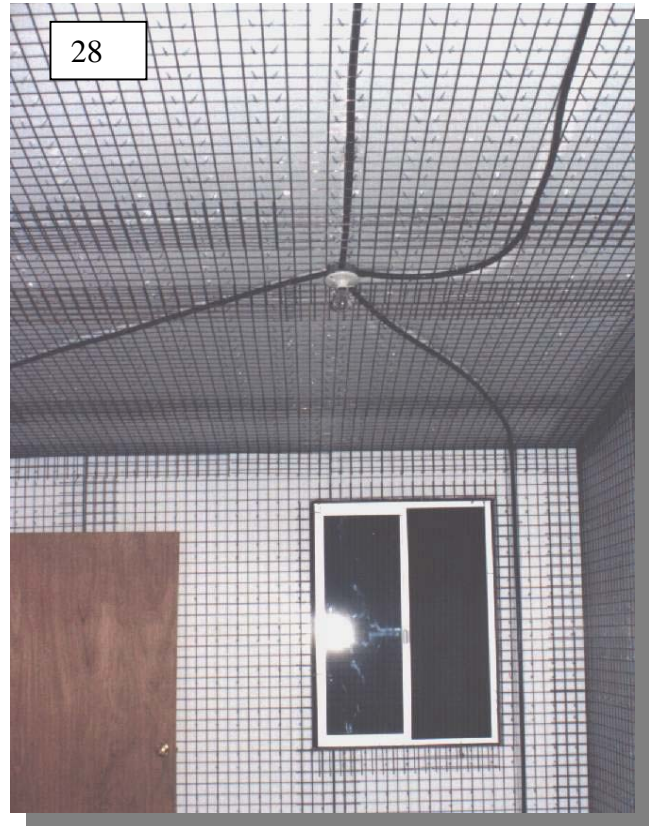

Cover all box and pipe openings and protect all water valve lines completely to prevent a build up of cement material during the concrete application process. Photo 30.



For mechanical chases it will be necessary to construct a passageway usually in a corner to house the larger pipes or lines. This can be accomplished by using narrow pieces or panel anchored in place using the pneumatic fastening gun. Don't forget to place cover mesh over the exterior corners.

This bathtub that will be later covered in concrete and finally with ceramic tile has been perfectly assembled with 3-D panel.

## VIII. Making Columns and Beams

Removal of some of the polystyrene panel may be necessary at times in order to strengthen a certain area by filling it in solid with concrete. Truss pockets are also created in the same fashion. Additional rebar may also be required in these cavities. You will find installation will be quick. Polystyrene removal can be achieved quickly by a variety of means. One of the best methods to efficiently remove this material is to use a high-pressure water spray.

Another method involves the use of a propane torch ( plumber type ) to melt the polystyrene. Also, columns and beams can be formed with the scrap panel from window and door cutout material; this will permit the designer to form an architectural element very easily. Photo 31 & 32.

A bond beam or column can be located anywhere within the 3-D wall system. This is accomplished by shotcreting one side of the panel and then removing the polystyrene from the other side where the beam or column is required. The resulting void is then filled solid with concrete when shotcreting that remaining side. Photo 34.

Filling the beam can also be accomplished when pouring a concrete roof if that is the case. The placement of beams and columns shall comply with plans designed according to the Uniform Building Code or other applicable codes.

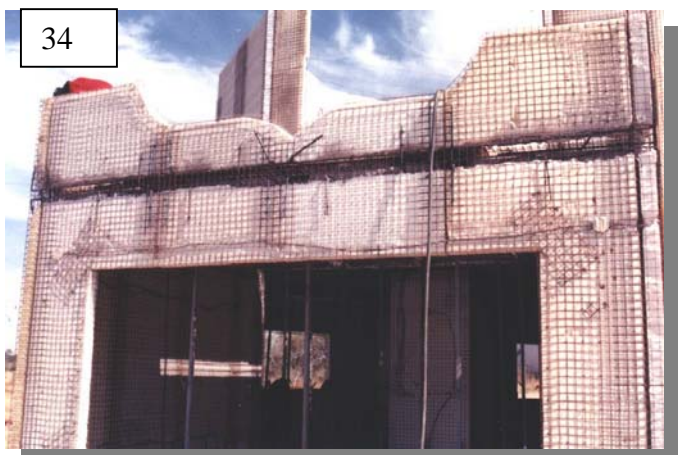

## **IX. Shotcreting**

No attempt will be made here to cover all the features necessary to achieve good shotcreting work. What will be covered is a general overview of the process with specific comments as it relates to the 3-D Panel System. All shotcrete use and design shall comply with Section 2621 of the Uniform Building Code or ACI 506 whichever is applicable

Covering the 3-D panels with concrete can be achieved by a variety of methods. The 2" x 2" panel mesh and the cover mesh provides reinforcing for this coating.

Concrete thickness varies, but usually it is twice the distance between the face of the polystyrene and the cover mesh. In most cases, plans call for 1-1/2" of concrete on each side of the panel. Note that applying the proper depth of concrete on the panels is critical in the 3-D system.

Before any mortar work begins, check with the appropriate building official regarding any test specimen preparation and compliance with Section 306 (A) 12 of the UBC, if applicable. Also check to see that all panel alignment and plumb is good and that openings of switch boxes, pipes, etc. are properly covered. Also sight down walls to be sure all cover mesh is flat against the panel mesh.

### **No Short Cuts Here**

It is not necessary to have all panel work completed before shotcreting begins. Often the exterior walls will be shot before utility



installation is complete.

This feature of the **3-D** system allows for much faster job completion. A word of caution here, if shotcreting and other work is to take place simultaneously, careful planning is necessary to see that crews do not get in each other's way.

Various systems may be employed to apply concrete to the panel surface. Each system has its own unique method of screeding and finishing to achieve the desired surface. The type of system to be used is determined by the structure to be built. Recommendations by PANELMEX will assist you in using the best method.

Proper shotcreting dictates that the spray nozzle must be held approximately perpendicular to the work face. Therefore, some means must be provided to allow the shotcrete nozzle man to move up and down the entire panel height as well as its width.

The weight of the nozzle and line prevents holding the nozzle above the head for a long period of time. All of this means that some type of scaffolding or lift is necessary in almost all cases. Be sure adequate room is allowed for this equipment.

It is recommended that shotcreting begin at the base of the panels and work upwards. PANELMEX recommends that standard shotcreting practices as outlined in ACI 506R-85 or Section 2621 of the Uniform Building Code be followed. (Again, whichever is applicable.)



All methods of shotcreting create some quantity of rebound (mortar that fails to stick while shotcreting). The amount of rebound produced is governed by a number of factors. Removal of this rebound presents problems at times and should be considered when making plans for your job. In all cases, it is not acceptable to reuse this rebound material as aggregate in the shotcrete mixture.



42

After the concrete is applied, a wide variety of finish materials can be used to complete the your project, materials that will ensure a beautiful building for years to come. Photo 42.

This same Residence can be seen at the assembly and roof phase on page 7



Manual tools that will be helpful in the application of concrete on certain hard to reach areas have also been designed.

Also, these tools are very widely used in areas or countries where the availability of Shotcrete pumps is very rare.

These tools are called “**Hopper Guns**” and they can be supplied by Hadrian Tridi-System



RECOMMENDED TOOLS AND MATERIALS FOR BUILDING WITH THE  
**TRIDIPANEL** 3-D/EVG SYSTEM.

1. **Pneumatic fastening tool**
2. **Fastening Rings**  
**16 ga. Galvanized rings for the pneumatic tool )**
3. **Reciprocating saw ( 8' metal cutting blade with 20-94 teeth  
per inch)**  
**This tool can be substituted by a regular 18" bolt cutter.**
5. **Wire loop ties**  
**To secure panels to reinforcing steel)**
6. **Basic hand tools for construction**  
**(must include Level - minimum 4-ft. to true-up panels)**
7. **Concrete pump for pneumatic application of concrete**  
**(Can be shotcrete, gunite or mortar pump)**
8. **Screed material**  
**(Can be stucco screeds. plastic pipe or wire guides)**
9. **Finishing tools**  
**(Trowels, sponges, darbys, or any other hand tool**